

Marine engine development for future renewable fuels

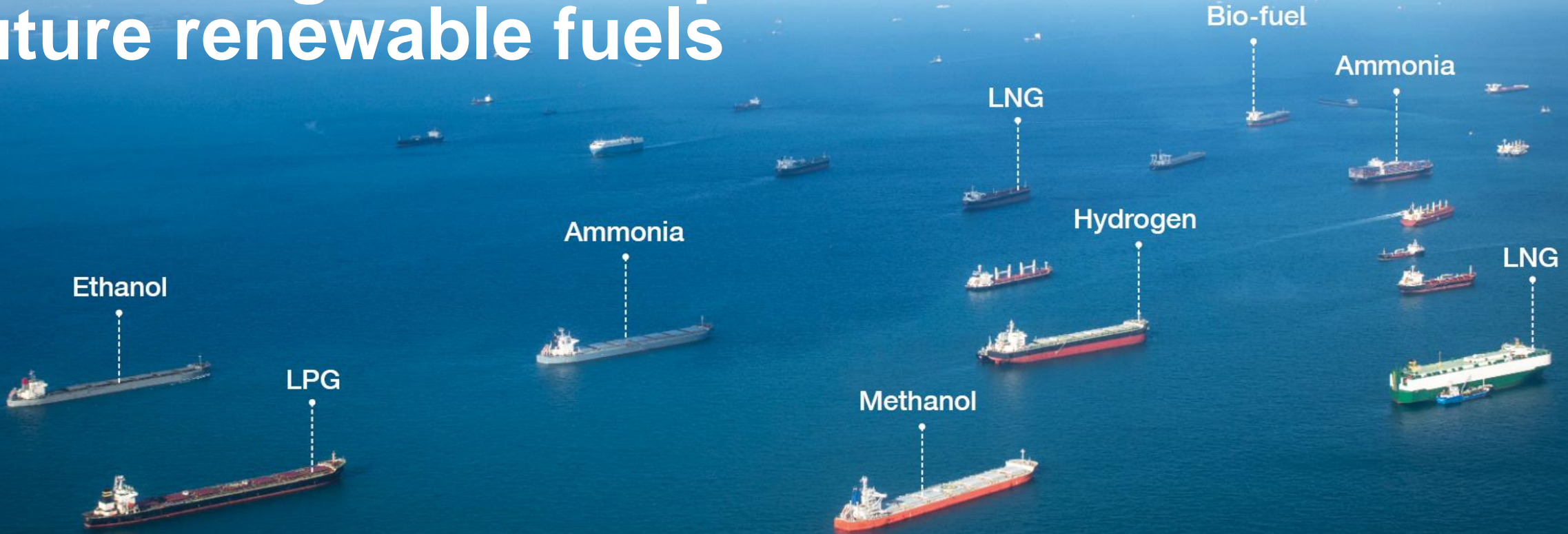

Dorthe Jacobsen
Principal Research Engineer: Fuel & Emissions
Engine Process Development
Low Speed

Copenhagen, 11th May 2022

Christiansborg conference om maritime emissioner

Agenda

- 1 Drivers for change**
- 2 Pathways to decarbonisation**
- 3 Future engines**
- 4 NOx reduction equipment**
- 5 Conclusion**

1 Drivers for change

Drivers for change

Public pressure + Regulation + Technology development



Market introduction: NOx reduction technology

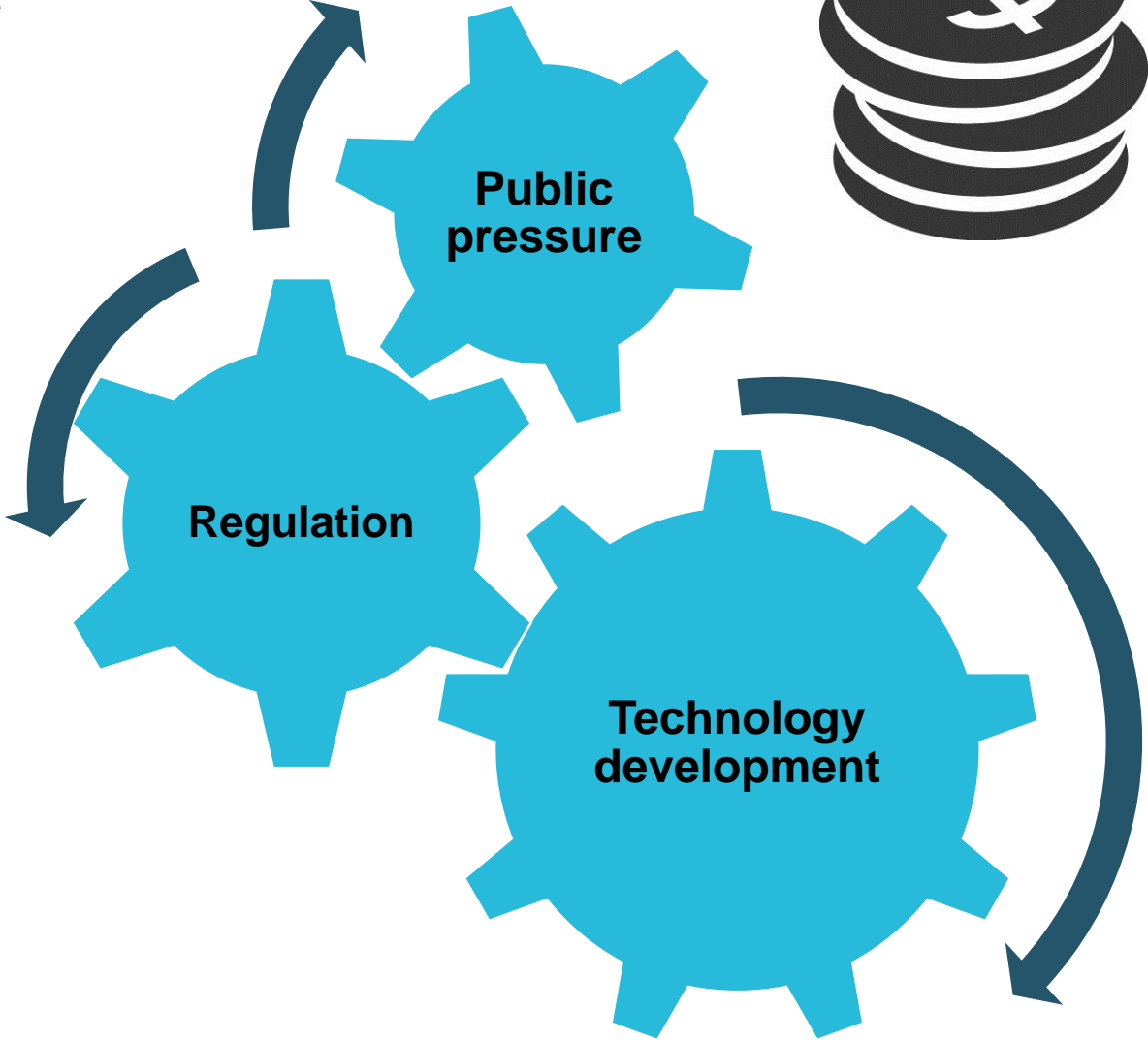
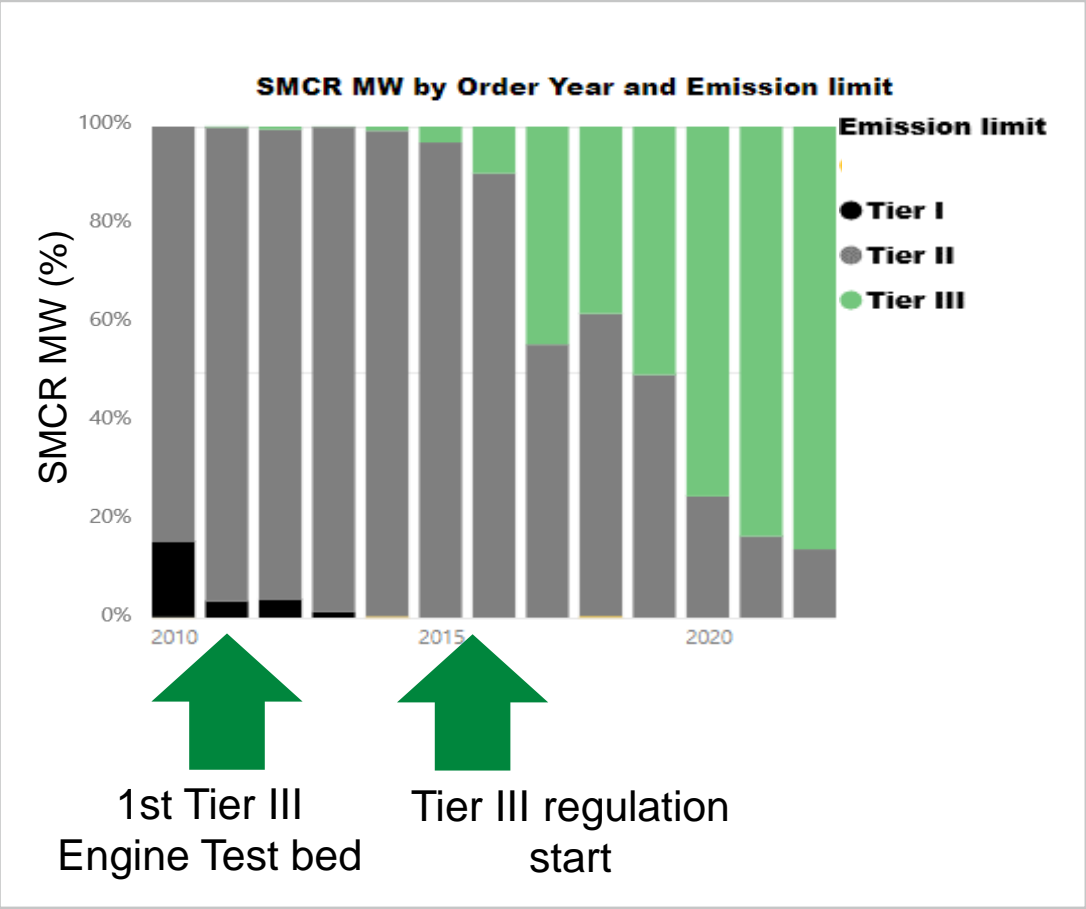

We may hit the target in 2050, but change comes too late

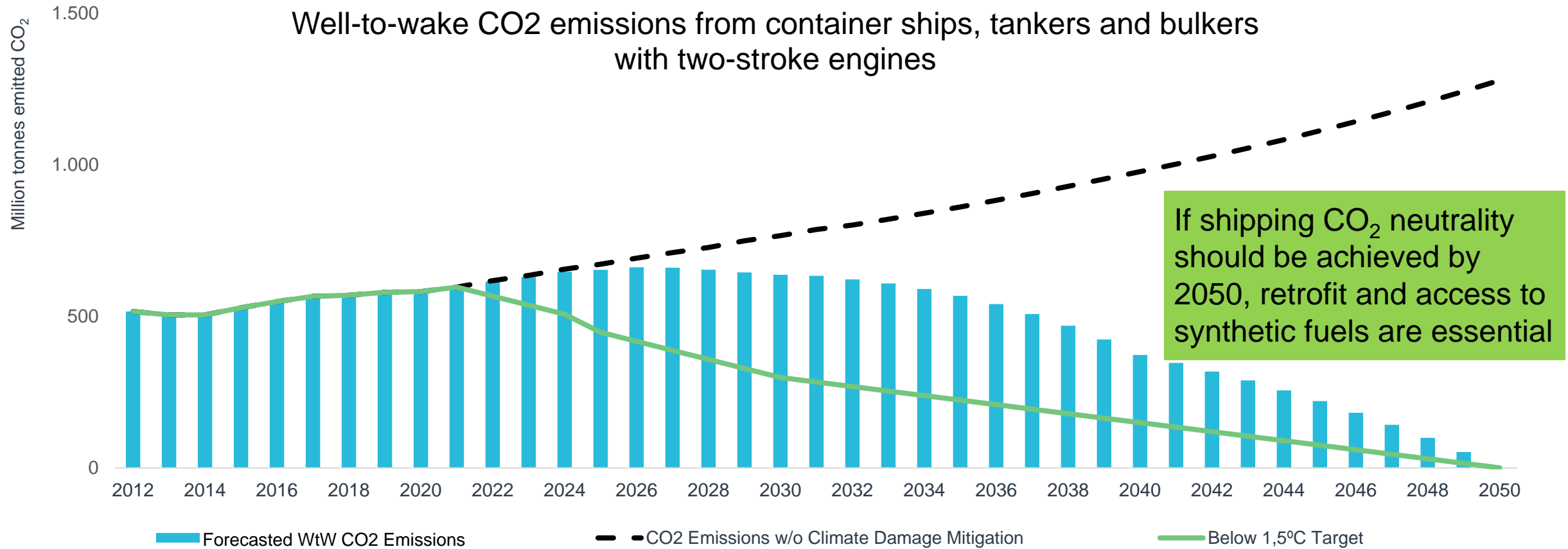

Source: IHS Markit/ IPCC/ FMS MAN ES Dec 2021

2 Pathways to decarbonisation

Shipping has significance in relation to climate change

~ **80-90%** of global freight is transported by sea.

Shipping is responsible for ~ **3%** of the global CO₂ emissions.

~ **50 %** of global freight is transported by a MAN engine.

MAN engines are 'responsible' for ~ 1.5% of the global CO₂ emissions.

MAN Energy Solutions is committed to decarbonization

Shipping has significance in relation to climate change

~ 80-90% of global freight is transported by sea.

Shipping is responsible for ~ 3% of the global CO₂ emissions.

~ 50 % of global freight is transported by a MAN engine.

So what are the pathways to decarbonization?

MAN engines are 'responsible' for ~ 1.5% of the global CO₂ emissions.

MAN Energy Solutions is committed to decarbonization

GHG reduction cost curve

Ball park figures - illustrational purposes only

Cost involves CAPEX and OPEX for engine and upstream technology!

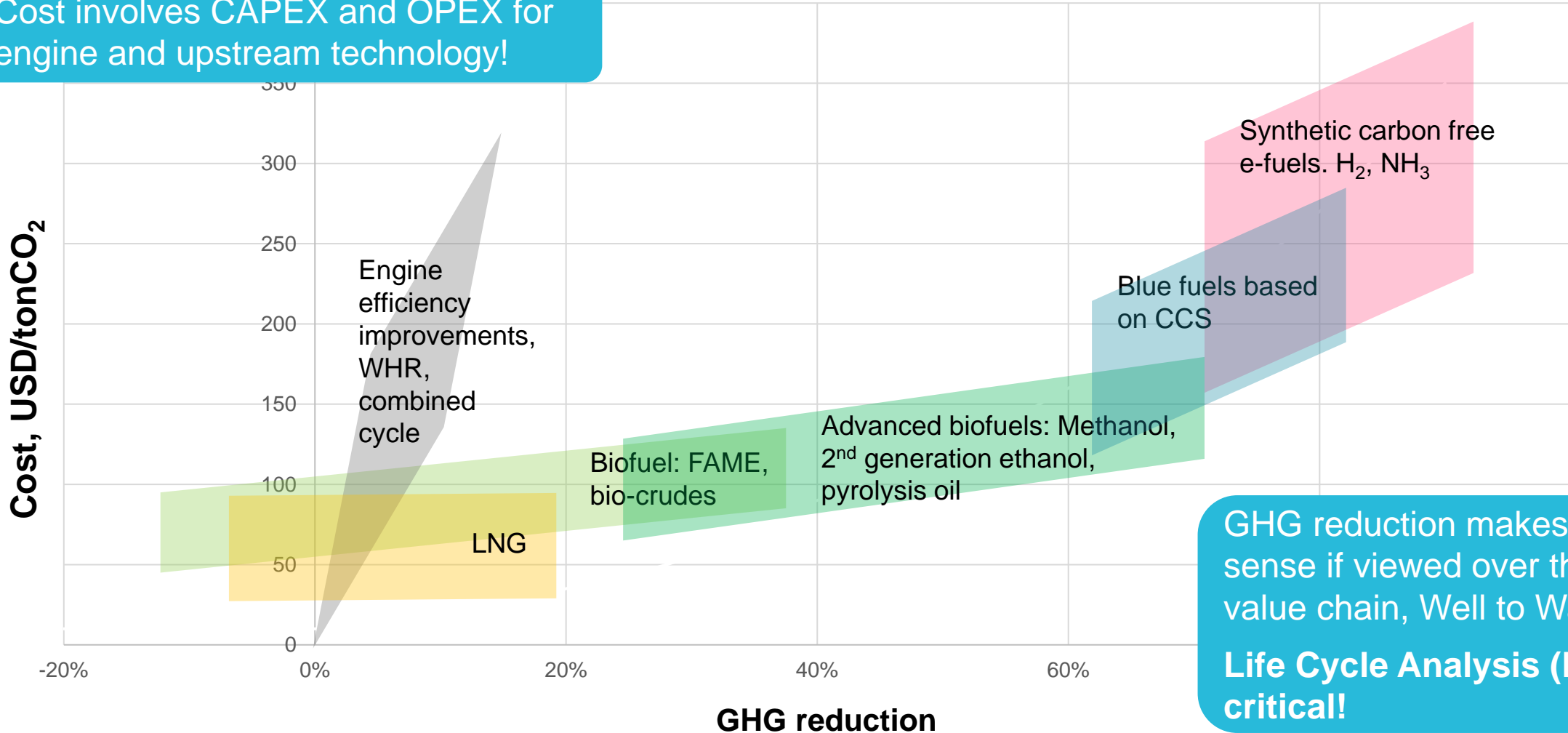

GHG reduction makes only sense if viewed over the entire value chain, Well to Wake:
Life Cycle Analysis (LCA) is critical!

3 Future engines

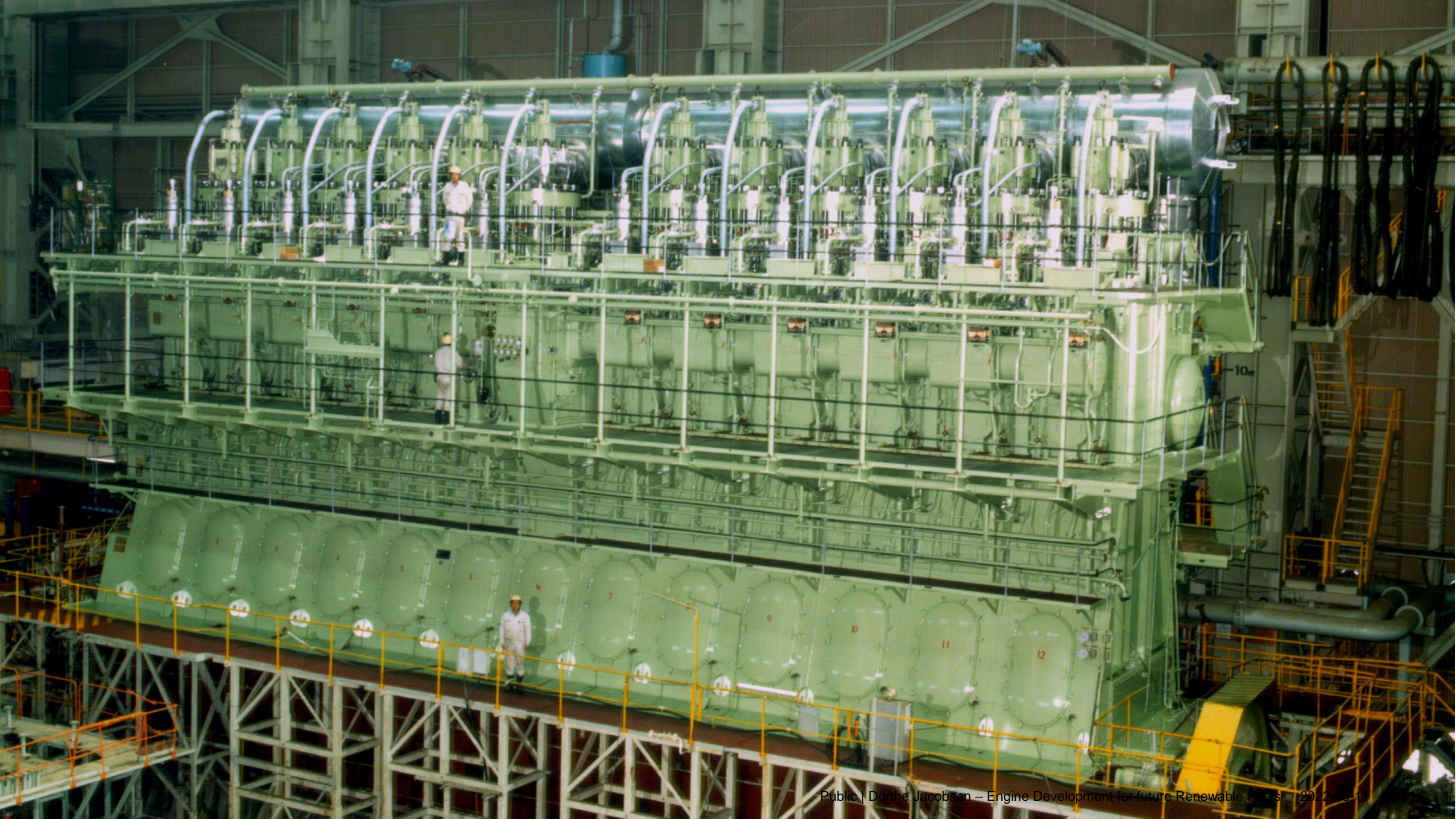

Application of low speed two-stroke engines



Marine low speed two-stroke engines

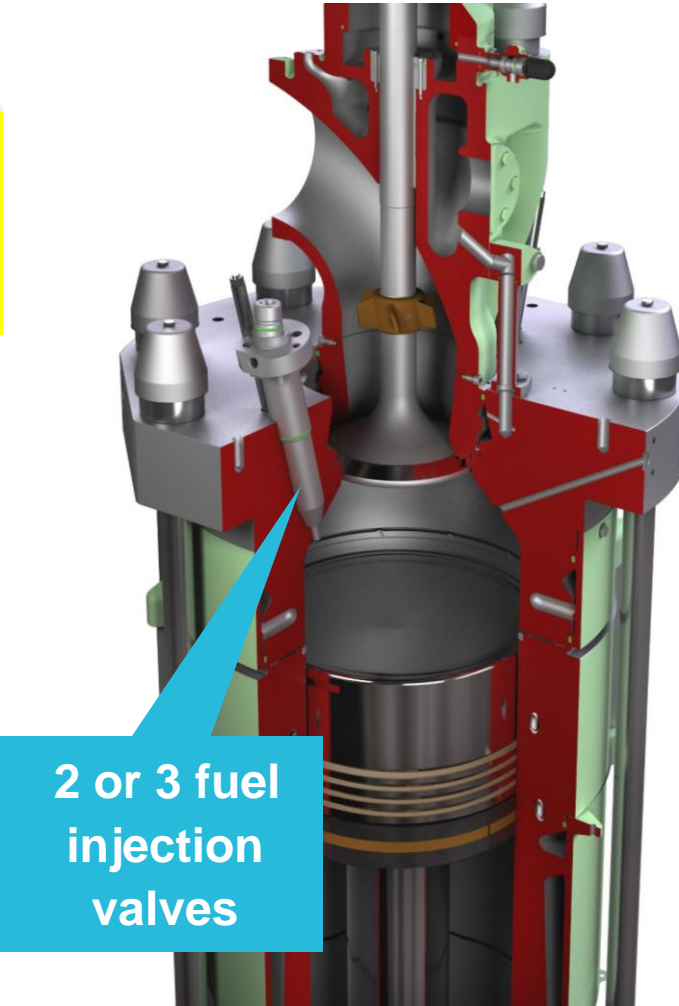
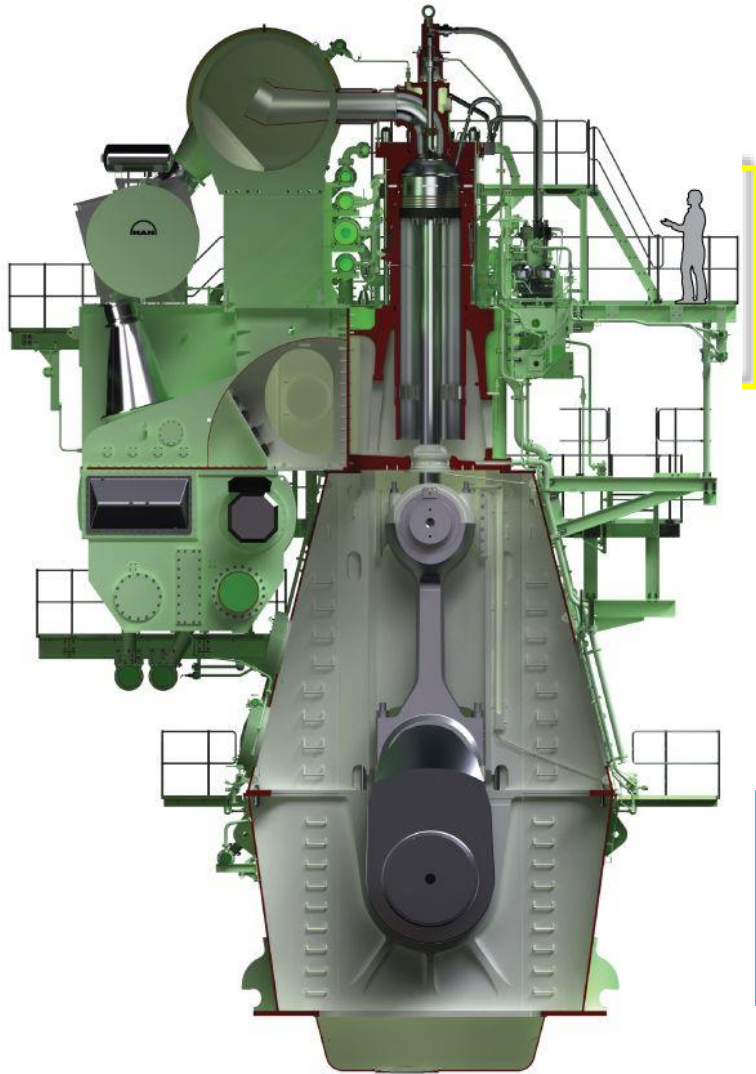

Design basis baseline engine:

- Multiple fuels are possible
- Typical fuels are distillate and heavy fuels
- Rather insensitive to fuel quality
- Direct drive of the propeller
- Bore sizes: 350-950 mm
- Stroke up to 4 m
- Typical engine speed at full load: 60-100 RPM
- Thermal efficiency around 50%
- With waste heat recovery/combined cycle: up to 60% efficiency is possible

MAN B&W dual-fuel engines: ME-GI and ME-LGI

Two injections systems:

- The **first fuel injection** system for conventional marine fuels
- The **second fuel injection** system for alternative fuels

Two operation modes:

- The diesel oil/heavy fuel mode (**first fuel**)
- The **Second fuel** mode:
 - **Second fuel** injected close to TDC and burned as non-premixed (Diesel-like).
 - Ignition is ensured by pilot injection from the primary system (**first fuel**)

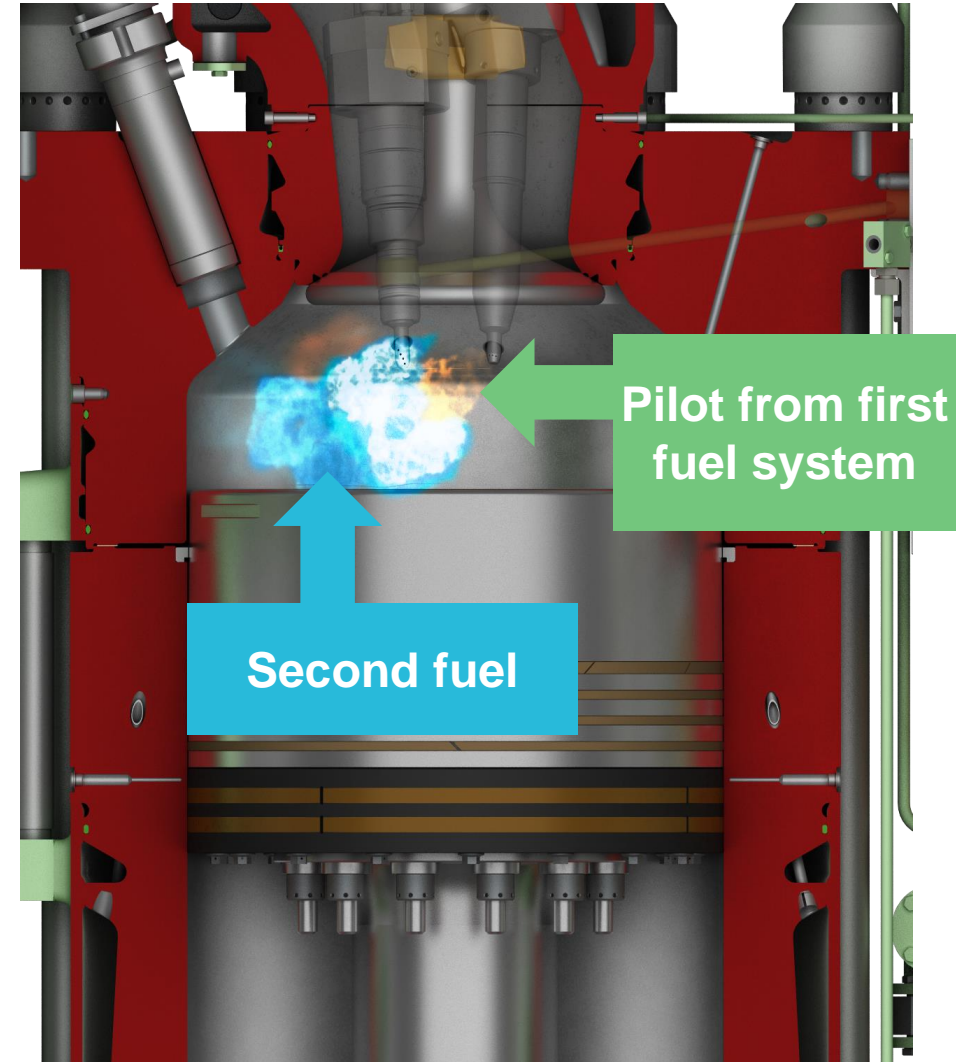

AN B&W dual-fuel engines: ME-GI/E and ME-LGIM/P

Two injections systems:

- The **first fuel injection** system for conventional marine fuels
- The **second fuel injection** system for alternative fuels

Two operation modes:

- The diesel oil/heavy fuel mode (**first fuel**)
- The **Second fuel** mode:
 - **Second fuel** injected close to TDC and burned as non-premixed (Diesel-like).
 - Ignition is ensured by pilot injection from the primary system (**first fuel**)

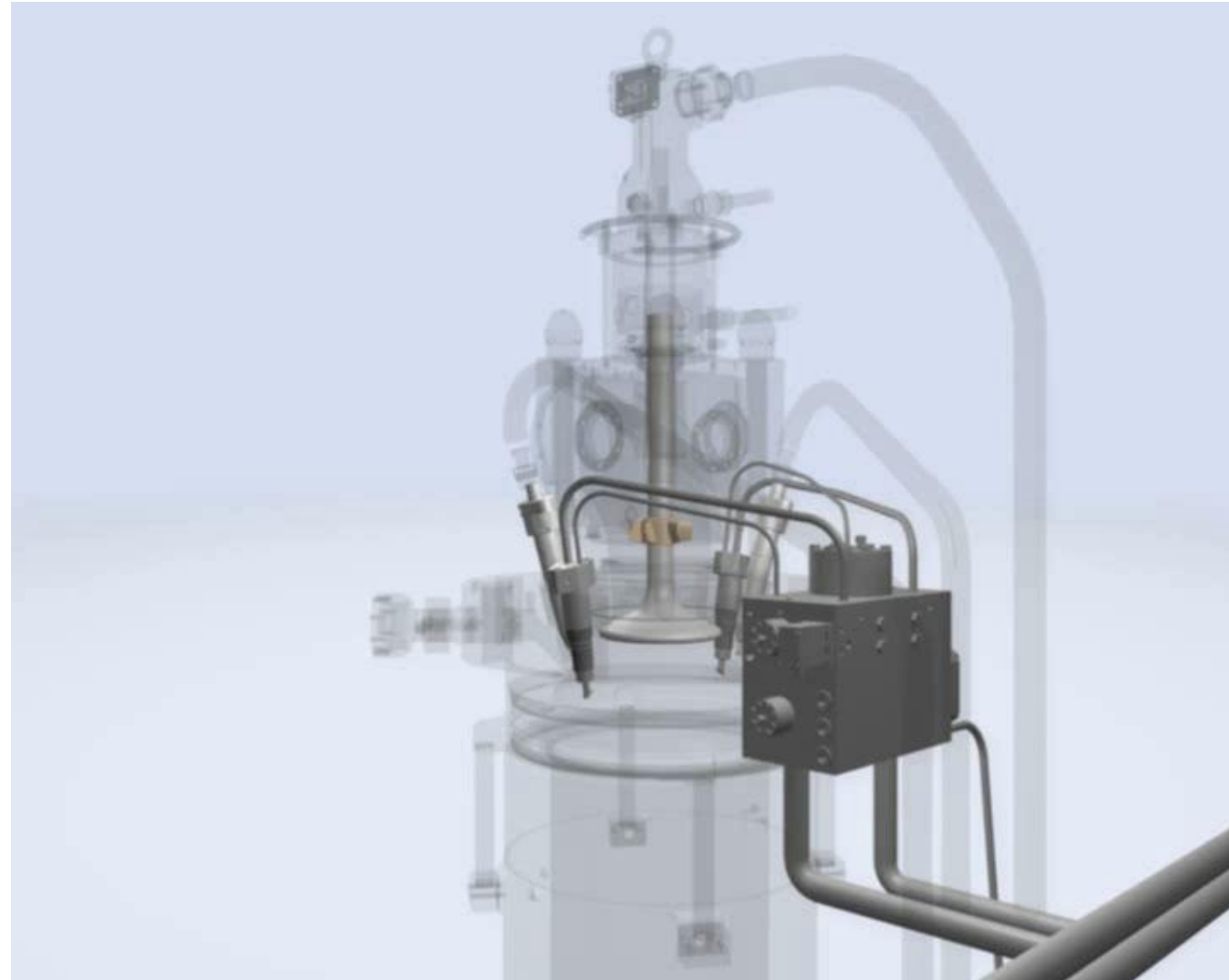

The dual-fuel successes

4 x world's first dual-fuel-driven ships equipped with MAN B&W engines



LNG:

First owner: TOTE

Ship type: container ship, 3,100 teu

Dual-fuel engine type: 8L70ME-C8.2-GI

Methanol:

First owner: MOL

Ship type: methanol carrier, 50,000 dwt

Dual-fuel engine type: 7S50ME-B9.3-LGIM

Ethane:

First owner: Hartmann Schifffahrt

Ship type: LEG carrier, 36,000 m³

Dual-fuel engine type: 7G50ME-GIE

LPG:

First owner: BW Gas (as retrofit)

Ship type: VLGC, 80,000 m³

Dual-fuel engine type: 6G60ME-LGIP (retrofit)

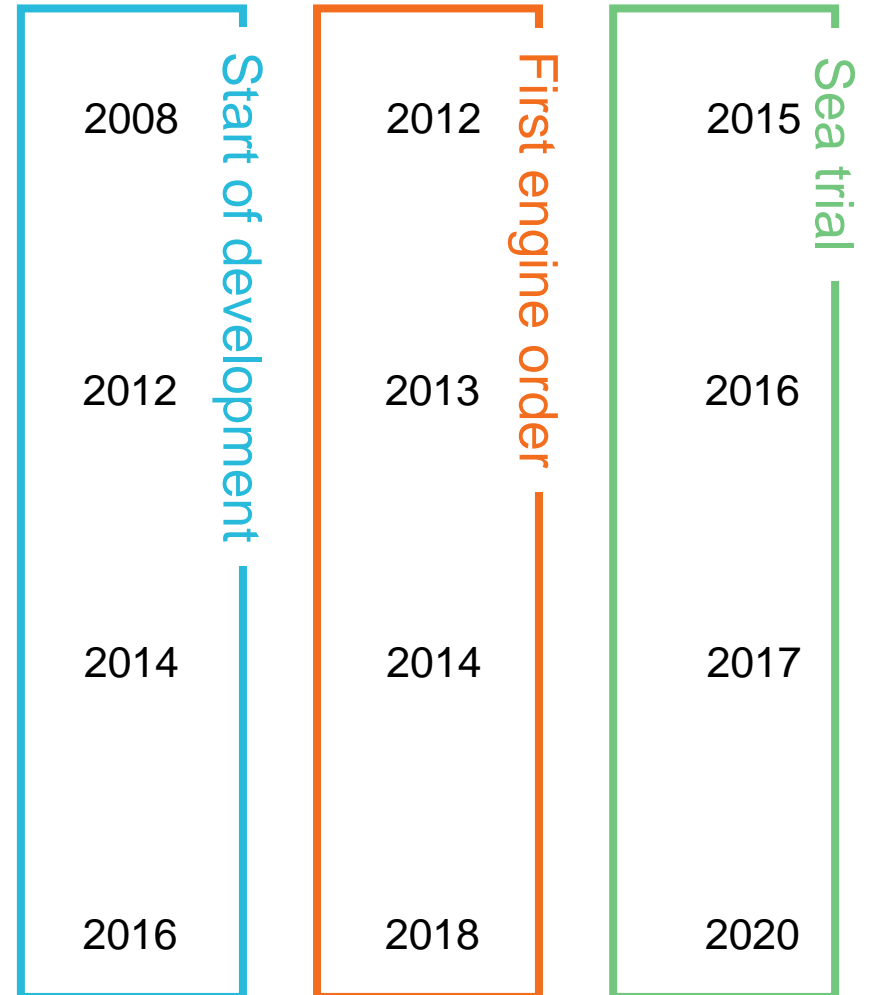

Market of dual-fuel engines

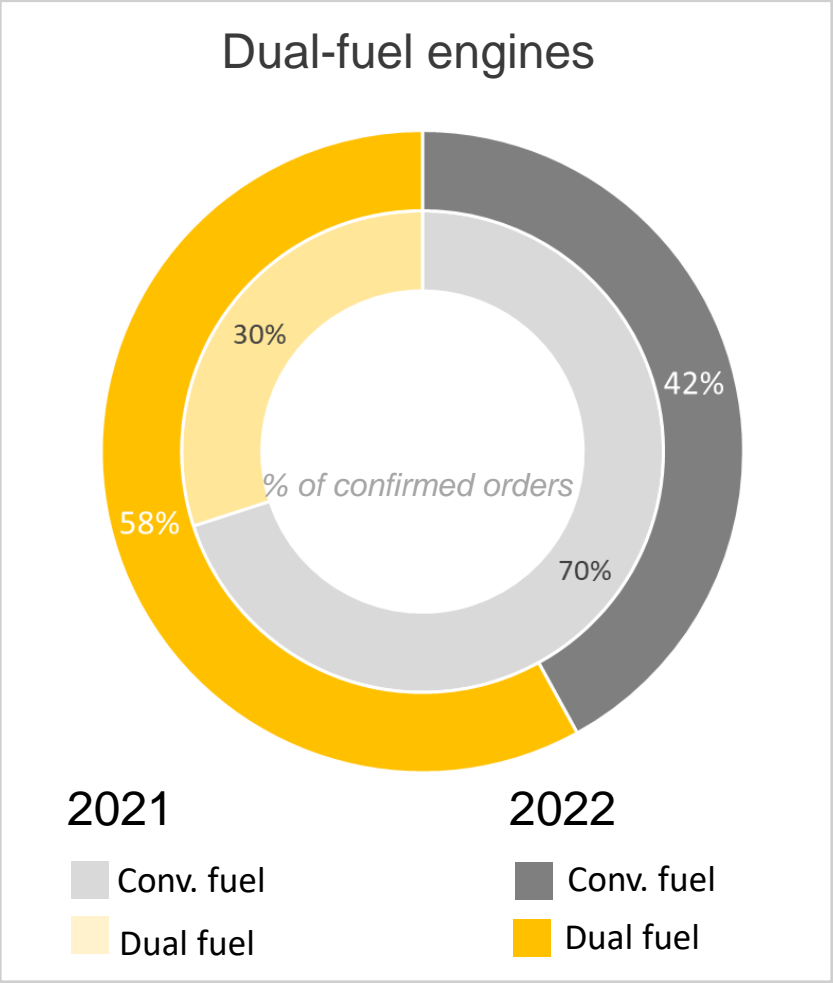
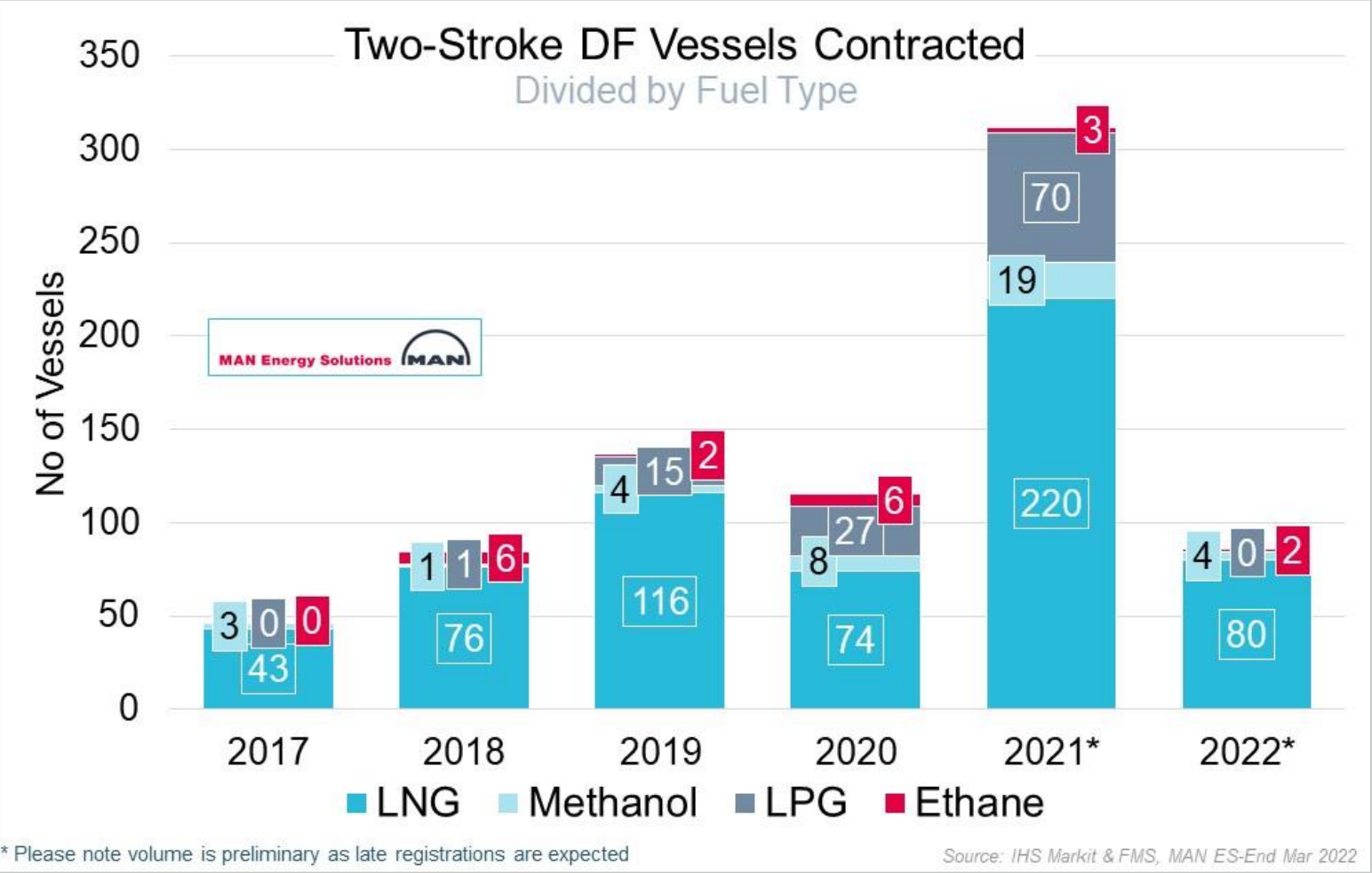

MAN B&W engines for different fuels

Modular design enables extensive retrofit options, and MAN Energy Solutions future proof your investment

Fuel types	MC	ME-B	ME-C	ME-GI	ME-GA*	ME-GIE	ME-LGIM	ME-LGIP
0-0.50% S VLSFO	Design	Design	Design	Design	Design	Design	Design	Design
High-S HSHFO	Design	Design	Design	Design	Design	-	Design	-
LNG	-	-	Retrofit**	Design	Design	Design	Retrofit**	Retrofit**
LEG (Ethan)	-	-	Retrofit**	Retrofit**	-	Design	Retrofit**	Retrofit**
Methanol / Ethanol	-	-	Retrofit**	Retrofit**	-	Retrofit**	Design	Retrofit**
LPG	-	-	Retrofit**	Retrofit**	-	Retrofit**	Retrofit**	Design
Biofuels	Design	Design	Design	Design	Design	Design	Design	Design
Ammonia***	-	-	(Retrofit**)	(Retrofit**)	-	(Retrofit**)	(Retrofit**)	(Retrofit**)

*Otto-cycle gas engine.

**Only one second fuel per retrofit.

*** Ammonia burning engine development started.



For description of MAN ES 2-stroke engine types:
<https://marine.man-es.com/two-stroke/2-stroke-engines/overview>

4 NOx Tier III technology

NOx Emission Controlled Areas – Tier III

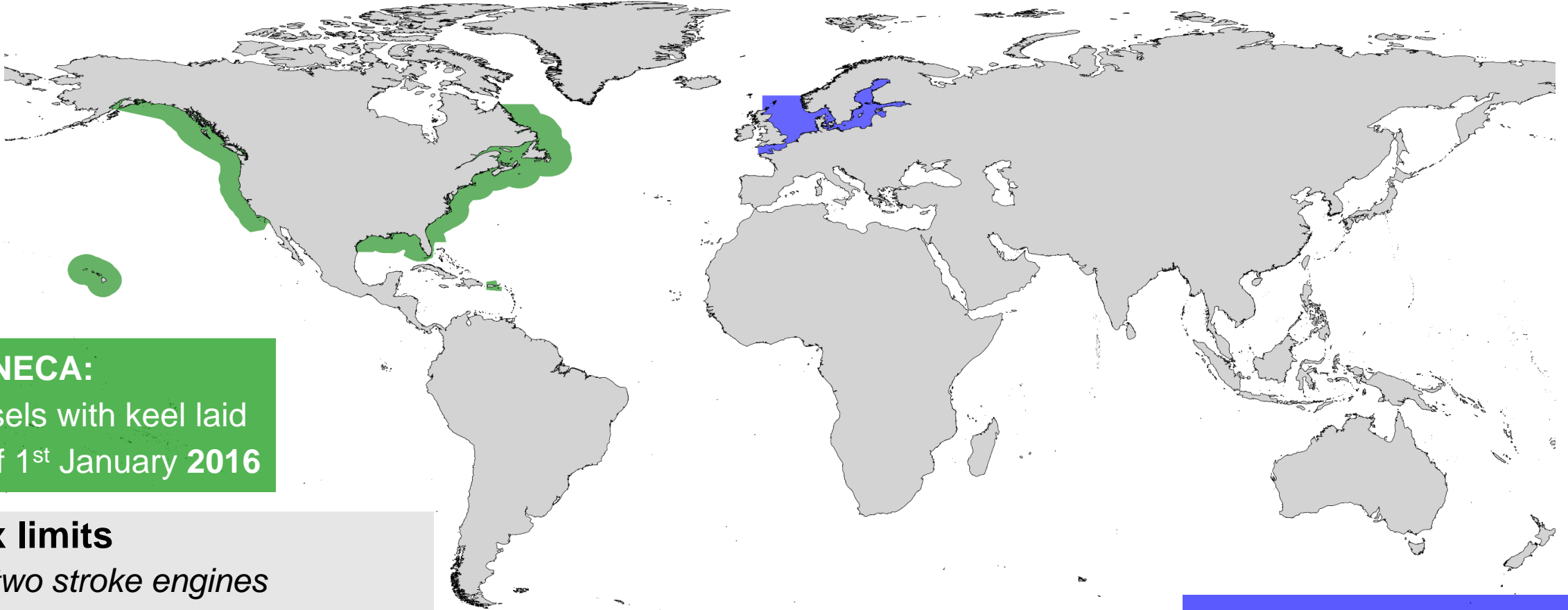

US NECA:
Vessels with keel laid
as of 1st January 2016

NOx limits
For two stroke engines
Tier II 14.4g/kWh (cycle)
Tier III 3.4g/kWh (cycle)
5.1g/kWh (Not to exceed)

New ships

Baltics, North Sea NECA:
Vessels with keel laid as
of 1st January 2021

NOx from two-stroke engines

Tier II and Tier III

Schematic example

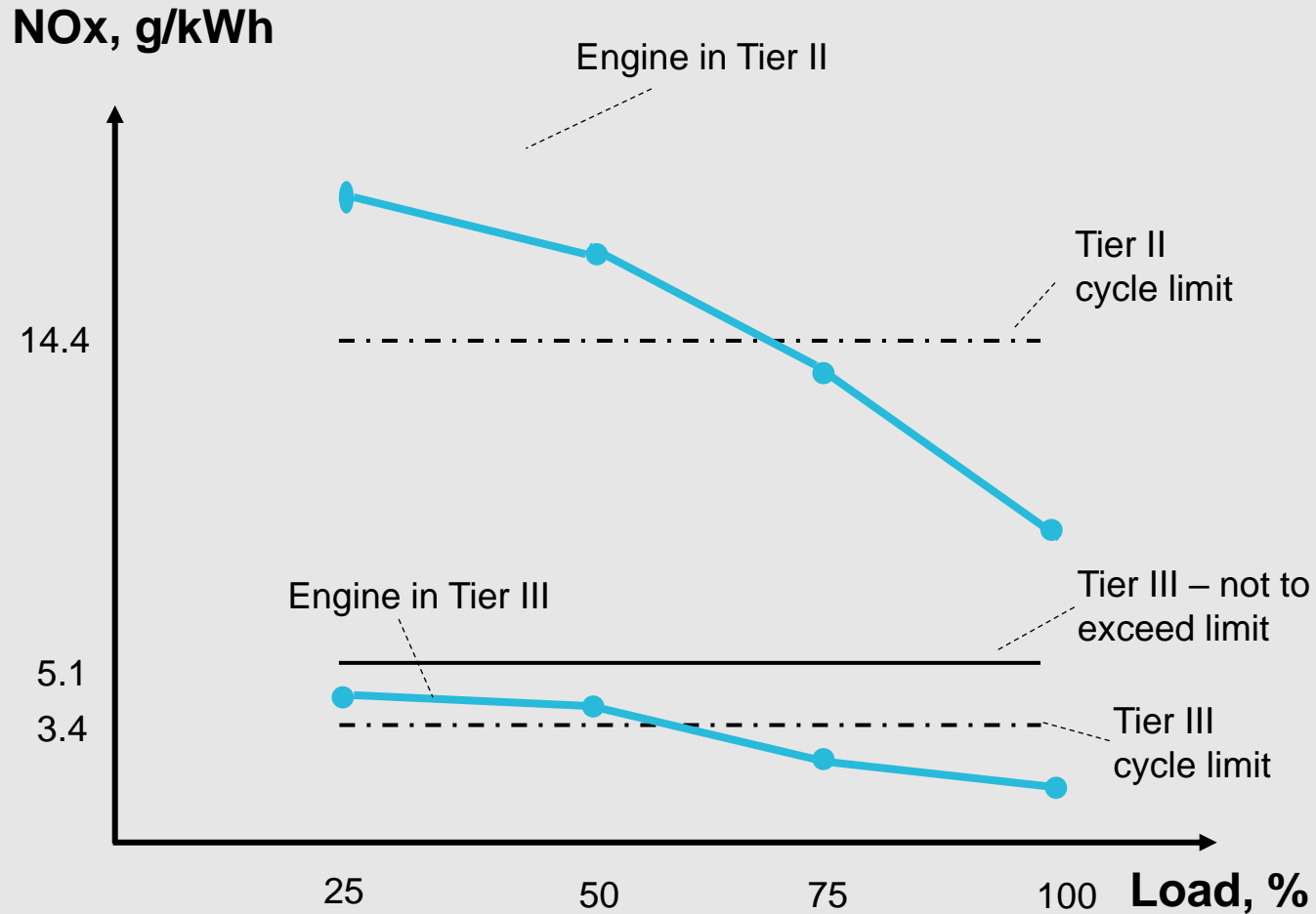

"Diesel dilemma"

Emissions

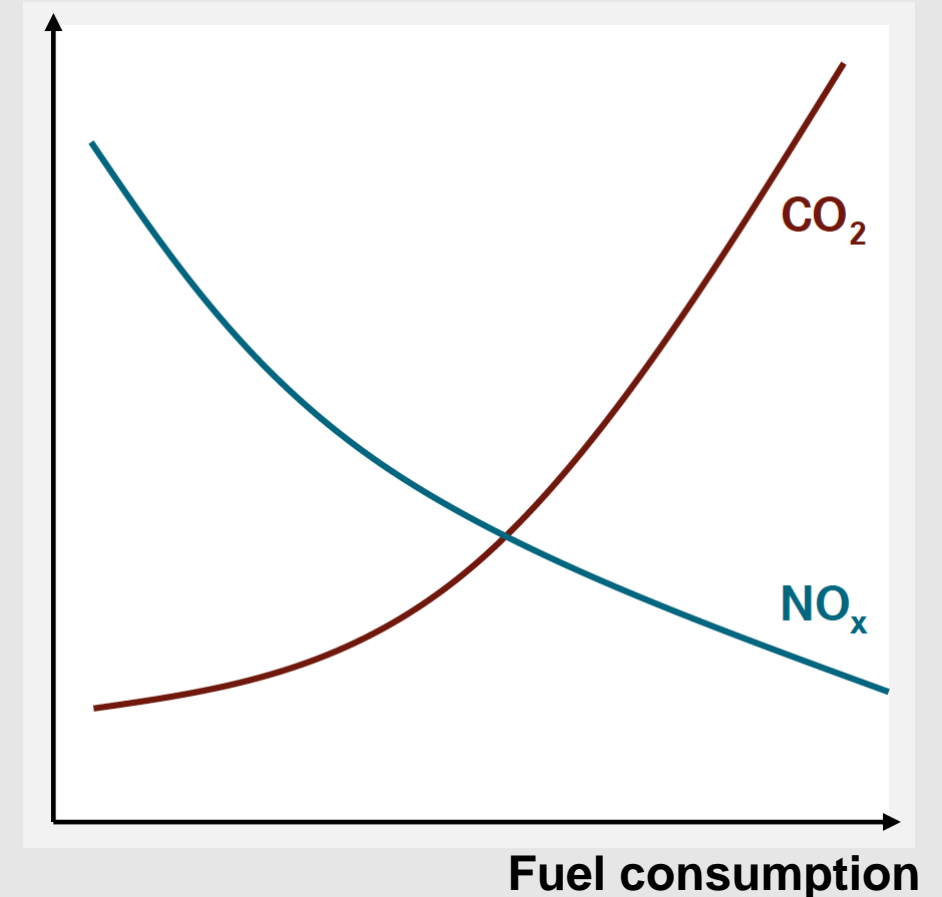

NOx Tier III technology overview

Fuel types

Fuel type	Technology*					
	EGR	HP-SCR	LP-SCR	LGIM-W	PIFIW**	
ULSFO-DM	■	■	■		■	
ULSFO-RM						
VLSFO						
HSFO						
LNG (ME-GI)			■			
LNG (ME-GA)						
MeOH						■
Ethane		■				
LPG						
NH ₃ **						



* Only one NOx Tier III equipment per engine can be ordered.

** Under development.
PIFIW only as back-up for LGIM-W.

5 Conclusion

A quick summary

- Focus emissions at present: GHG
- Large gap between current projections for future GHG footprint of shipping and the accepted IPCC 1.5 C target
- Decarbonization of shipping may well be based on:
 - Bio-oils
 - Renewable methanol
 - E-ammonia
- Life cycle analysis (LCA) of well to wake (WTW) value chain is critical for GHG reduction assessment
- MAN Energy Solutions offers ship engine technology for methanol and a wide range of bio-oils
- Development of an ammonia engine is underway – orders accepted from 2024
- **It is not the engine technology, that is the barrier for decarbonization of shipping – it is and will be the production capacity for renewable fuels!**

The way to zero carbon shipping

At least 50% GHG reduction in 2050 requires:

- Drivers (regulatory and/or economical)
- Major investments in energy/fuel production (upstream)
- Funding: Research, development and demonstration
- Cross-sectoral cooperation projects
- LCA approach to ensure net-GHG reduction
- **Implementation of new fuels to start by 2030 - preferably sooner**

**Work should start now
- and we all have our roles**

*) Getting to Zero Coalition: <https://www.globalmaritimeforum.org/news/the-scale-of-investment-needed-to-decarbonize-international-shipping/>

Investment breakdown across vessels and land-based infrastructure*

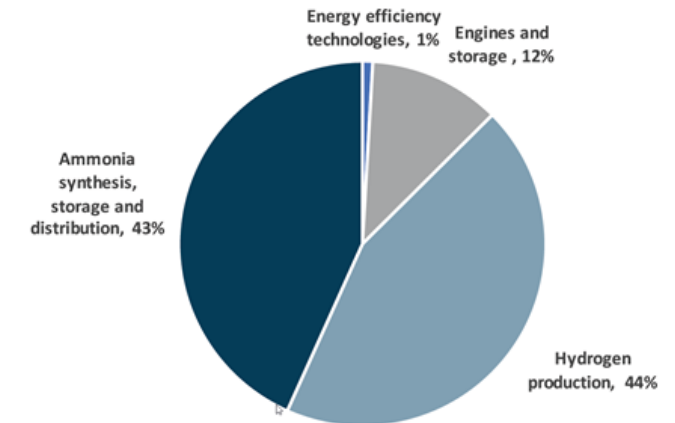

Life Cycle Analysis

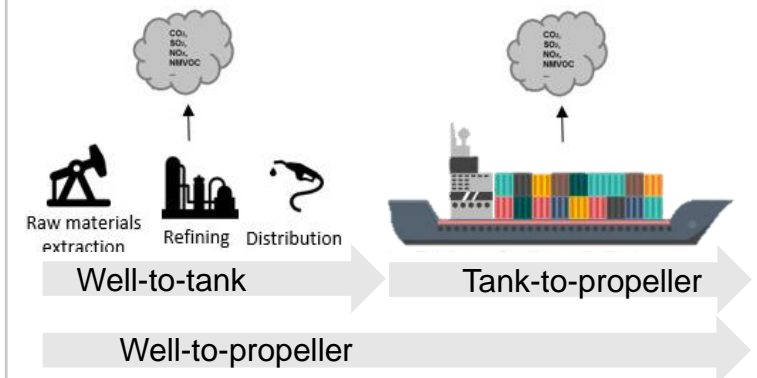



Thank you very much!

Dorthe Jacobsen, Engine Process Development
Low Speed